

## HOODS

# AVANTE-LPH

## LOW PROFILE HOOD



Avante Low profile kitchen hoods – Avante-LPH, also known as back shelf hoods or slim range hoods, are kitchen ventilation extract hoods designed to extract the cooking fumes from low proximity of the cooking equipment providing effective air extraction above cooking surfaces.

### APPLICATION

- Avante-LPH is designed with high-efficiency filtration capabilities and superior fire safety
- Avante-LPH is well-suited to all kitchens where the fumes are extracted near the source (Above deep fat fryers)

### ADVANTAGES

- Space-saving Design
- Efficient Ventilation
- Improved Visibility
- Easy Installation
- Lighting Features

### CUSTOMIZATION

- Wall mounted
- 1050mm height, 950mm depth, length varies according to layout requirements

### MAINTENANCE

- Dripping grease is arrested with vane and collected in an easily accessible grease tray

### OPTIONS

- LED dimmable spotlights
- Factory-installed hood Fire Suppression System
- Factory-installed hood Demand Control Ventilation System

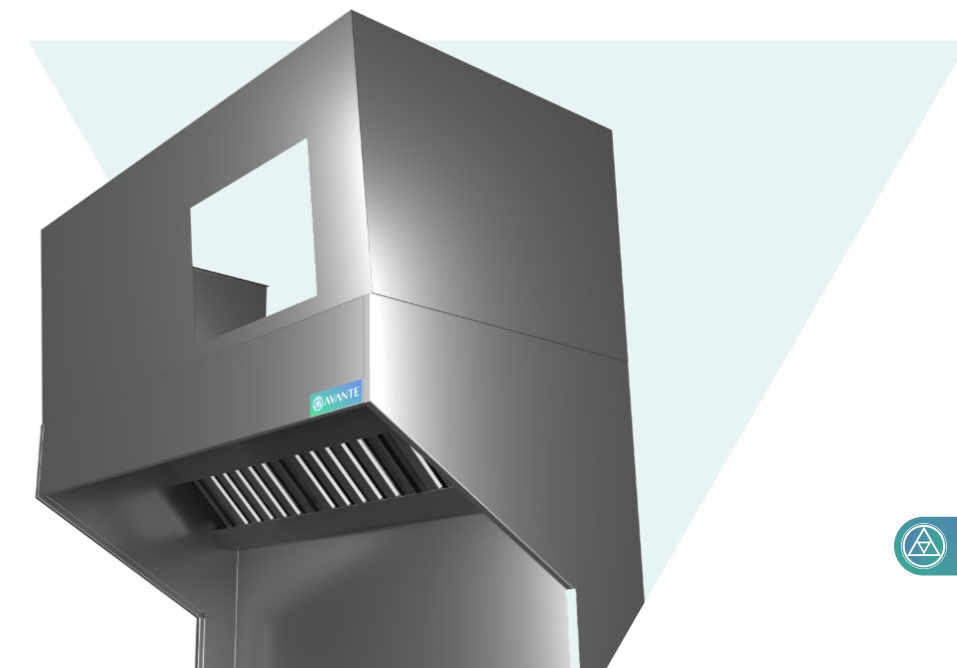

# HOODS

## AVANTE-LPH LOW PROFILE HOOD



### LIGHTING

- Factory-wired
- Energy efficient fluorescent or LED lights (500 lux on the working surface - IP65)
- Tempered glass light diffuser with heat tolerance up to 180°C

### FILTRATION

- Heavy duty Stainless Steel welded construction
- Filtration efficiency of 95% for 6-8 microns
- UL listed
- DMT certified for filtration efficiency
- Meets NFPA #96 requirements

### CONSTRUCTION

- Fully made of 1.2mm SS AISI 304 brush finish
- Welded construction
- Sliding balancing dampers
- Extract air flow calculations as per DW 172
- Modular construction

## TECHNICAL SPECIFICATIONS

### MATERIAL:

- SS AISI 304 brush finish
- Thickness: 1.2mm

### POWER SUPPLY:

- 120/220 - 240 V
- 50 - 60 Hz

### LIGHTING:

- Fluorescent or LED lights
- Rated IP65
- 500 lux on the working surface
- Low consumption
- Heat & vapor resistance
- Long-lasting

### DIMENSIONS:

- 1050mm height
- 950mm depth,
- Length: customized

### GREASE FILTERS CERTIFICATIONS:

[www.avanteuae.com](http://www.avanteuae.com)



# HOODS

## AVANTE-LPH LOW PROFILE HOOD

### TECHNICAL DRAWINGS

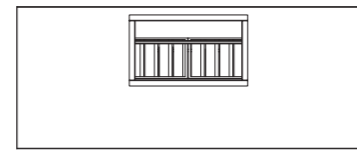
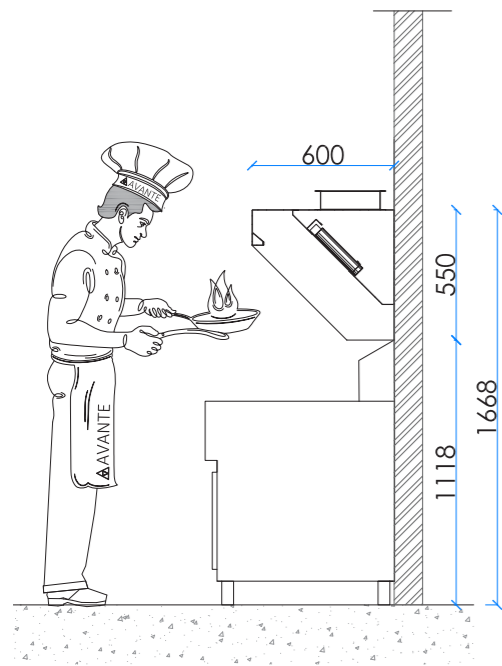

Top View

Section View

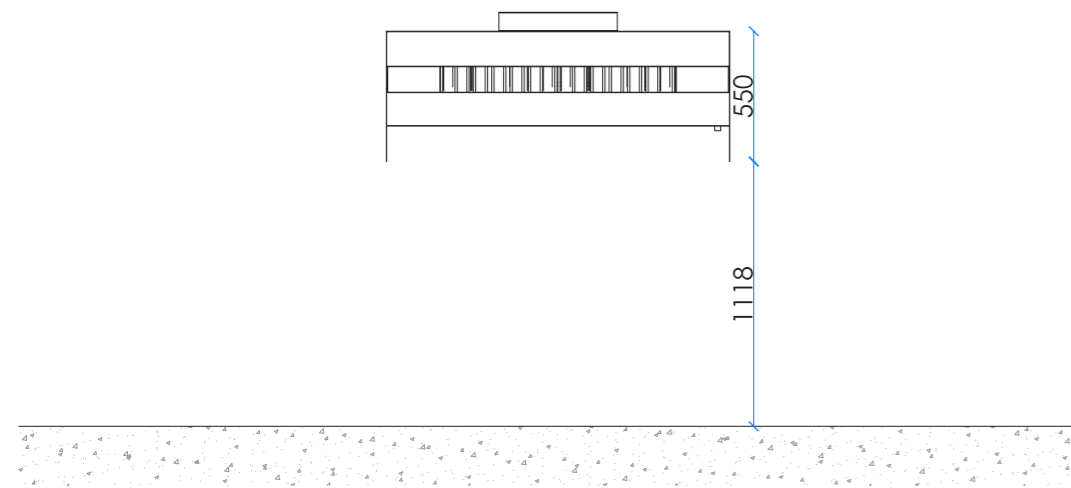

Front View

