

HOODS

AVANTE-EF-WM

HIGH EFFICIENCY EXTRACT-ONLY WATER MIST CANOPY WITH INDUCTION NOZZLES

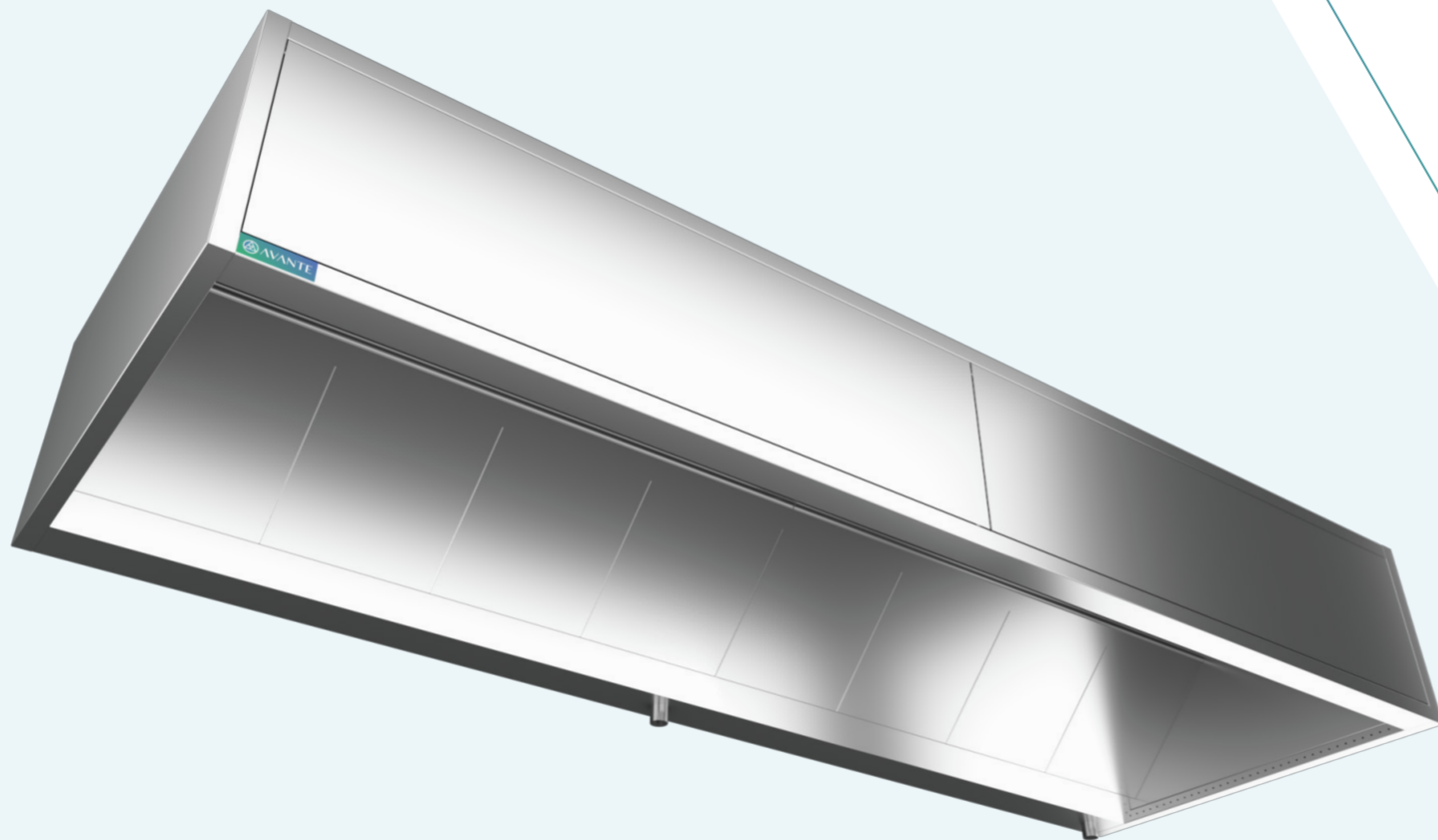

Avante-EF-WM is an extract-only canopy with Water Mist, equipped with front and side induction nozzles to contain and extract fumes and heat within the hood area, thereby improving the extract efficiency and working conditions. The front section is equipped with a fan that uses the ambient air from the surrounding area to supply air through the induction nozzles.

APPLICATION

- Avante- EF-WM hood is designed with high-efficiency filtration capabilities and superior fire safety
- Used on the top of the heavy-duty cooking appliances and acts as a spark and flame arrestor to prevent igniting FOG deposits building up in the ductwork
- Avante- EF-WM hood is well-suited to all types of commercial and professional kitchens

CUSTOMIZATION

- -Wall mounted
- Island mounted
- 600mm height, 1350mm depth (min), length varies according to layout requirements

MAINTENANCE

- Dripping grease is arrested with vane and connected to the grease trap

OPTIONS

- LED dimmable spotlights
- Service Distribution Unit
- Factory-installed hood Fire Suppression System
- Factory-installed hood Demand Control Ventilation System
- Hood cladding / powder coating

HOODS

AVANTE-EF-WM HIGH EFFICIENCY EXTRACT-ONLY WATER MIST CANOPY WITH INDUCTION NOZZLES

LIGHTING

- Factory-wired
- Energy efficient LED lights (500 lux on the working surface - IP65)
- Heat & vapor resistance
- Tempered glass light diffuser with heat tolerance of -40 to +180°C

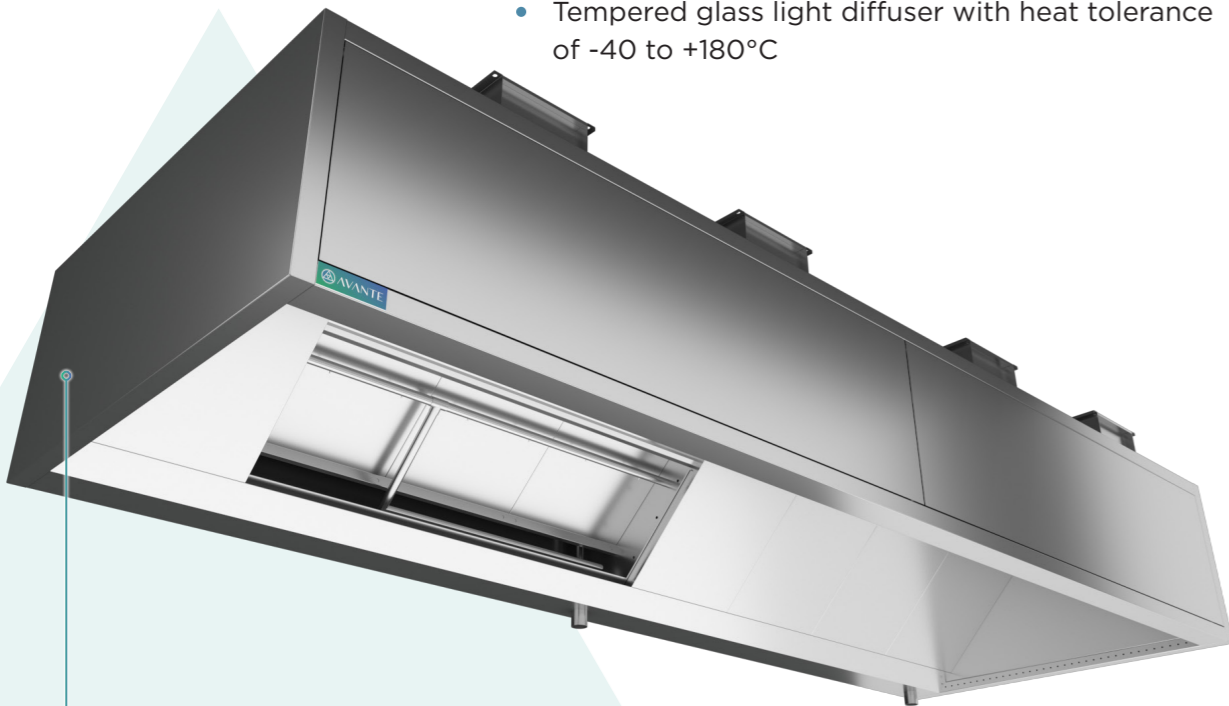

CONSTRUCTION

- Fully made of 1.2mm SS AISI 304 brush finish
- Double skin
- Welded construction
- Full-length induction nozzle slot on the front and sides to improve the extraction efficiency
- An aerodynamically designed baffle to direct the contaminated extracted air vertically down through the water mist nozzle
- Full-length filter housing with lift-off doors and SS water manifolds.
- Special brass mist nozzles and SS piping
- Sliding balancing dampers
- Extract air flow calculations as per DW 172
- Modular construction

TECHNICAL SPECIFICATIONS

MATERIAL:	<ul style="list-style-type: none"> • SS AISI 304 brush finish • Thickness: 1.2mm
POWER SUPPLY:	<ul style="list-style-type: none"> • 120/220 - 240 V • 50 - 60 Hz
MIST NOZZLES:	<ul style="list-style-type: none"> • Brass
MIST PIPE:	<ul style="list-style-type: none"> • Stainless Steel 304 • Thickness: 1.2mm
SAFETY FEATURES:	<ul style="list-style-type: none"> • Differential air pressure switch • Accessories
OTHER ACCESSORIES:	<ul style="list-style-type: none"> • Solenoid valve • Pressure reducing valve. • Water filter • Water strainer
LIGHTING:	<ul style="list-style-type: none"> • Fluorescent or LED lights • Rated IP65 • 500 - 600 lux on the working surface • Low consumption • Heat & vapor resistance • Long-lasting
DIMENSIONS:	<ul style="list-style-type: none"> • 600 mm (Height) • 1350 mm (Depth min) • Length: customized

www.avanteuae.com



HOODS

AVANTE-EF-WM HIGH EFFICIENCY EXTRACT-ONLY WATER MIST CANOPY WITH INDUCTION NOZZLES

TECHNICAL DRAWINGS

