

## HOODS

# AVANTE-SEF

## HIGH EFFICIENCY EXTRACT CANOPY WITH MAKEUP AIR AND INDUCTION NOZZLES

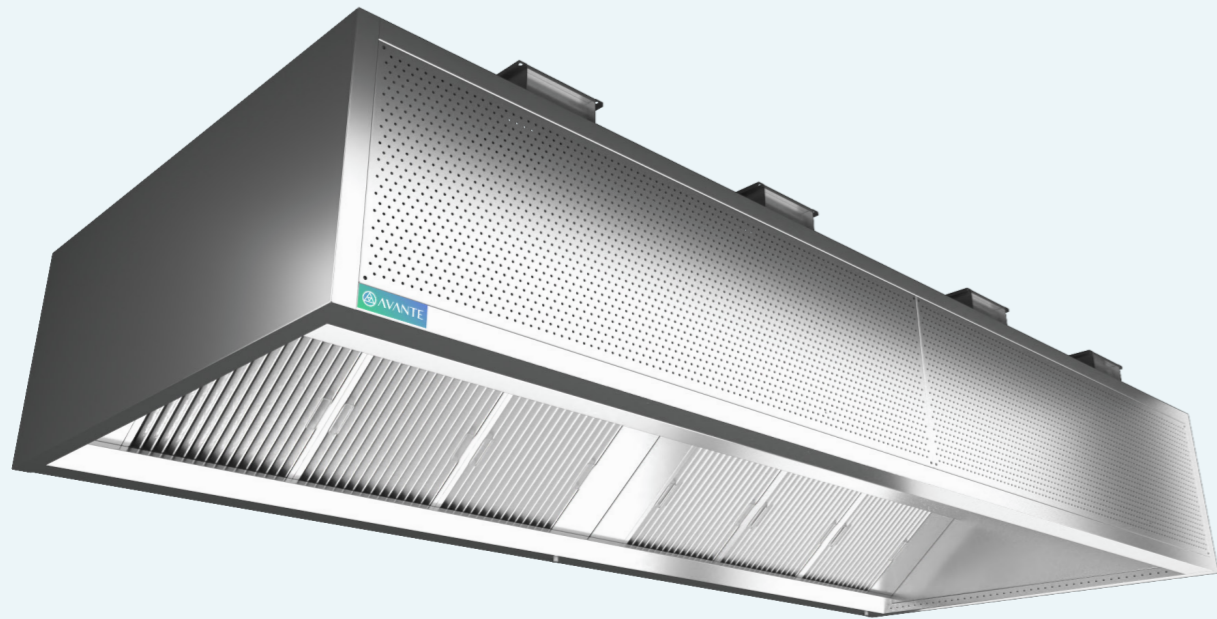

Avante-SEF canopy is an extract canopy with makeup air plenum equipped with front and side induction nozzles to contain and extract fumes and heat within the hood area, thereby improving the extract efficiency and working conditions.

The makeup air to the hood is from the front perforated plenum and treated makeup air is introduced at low velocity to the cooking space to improve the comfort in the cooking area.

The makeup air is integrated into the hood structure, and the plenum is insulated.

### APPLICATION

- Avante-SEF is designed with high-efficiency filtration capabilities and superior fire safety
- Avante-SEF is well-suited to all types of commercial and professional kitchens
- Equipped with a space-saving integrated makeup air system, featuring a double skin design that simplifies the balancing of kitchen air flows and eliminates the need for extra makeup terminals, leading to a project cost reduction

### CUSTOMIZATION

- Wall mounted
- Island mounted
- 600mm height, 1350mm depth (min), length varies according to layout requirements

### MAINTENANCE

- Dripping grease is arrested with vane and collected in an easily accessible grease tray

### OPTIONS

- LED dimmable spotlights
- Service Distribution Unit
- Factory-installed hood Fire Suppression System
- Factory-installed hood Demand Control Ventilation System
- Hood cladding / powder coating

# HOODS

## AVANTE-SEF

### HIGH EFFICIENCY EXTRACT CANOPY WITH MAKEUP AIR AND INDUCTION NOZZLES

#### FILTRATION

- Heavy duty Stainless Steel welded construction
- Filtration efficiency of 95% for 6-8 microns
- UL listed
- DMT certified for filtration efficiency
- Meets NFPA #96 requirements

#### LIGHTING

- Factory-wired
- Energy efficient fluorescent or LED lights (500 lux on the working surface - IP65)
- Tempered glass light diffuser with heat tolerance up to 180°C

#### TECHNICAL SPECIFICATIONS

##### MATERIAL:

- SS AISI 304 brush finish
- Thickness: 1.2mm

##### MAKEUP AIR:

- Front perforated SS AISI 304 brush finish insulated supply plenum

##### POWER SUPPLY:

- 120/220 - 240 V
- 50 - 60 Hz

##### LIGHTING:

- Fluorescent or LED lights
- Rated IP65
- 500 lux on the working surface
- Low consumption
- Heat & vapor resistance
- Long-lasting

##### DIMENSIONS:

- 600 mm (Height)
- 1350 mm (Depth min)
- Length: customized

#### GREASE FILTERS CERTIFICATIONS:

[www.avanteuae.com](http://www.avanteuae.com)



#### CONSTRUCTION

- Fully made of 1.2mm SS AISI 304 brush finish
- Double skin with front perforated supply section equipped with induction fan
- Welded construction
- Full-length induction nozzle slot on the front and sides to improve the extraction efficiency
- Sliding balancing dampers
- Extract air flow calculations as per DW 172
- Modular construction

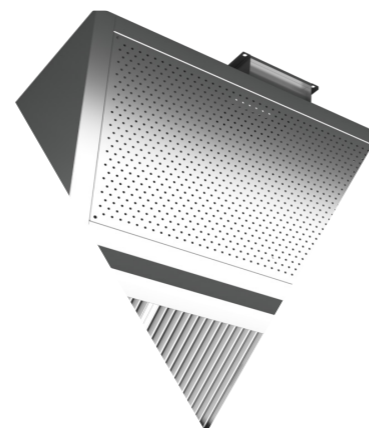

# HOODS

**AVANTE-SEF** HIGH EFFICIENCY EXTRACT CANOPY WITH MAKEUP AIR AND INDUCTION NOZZLES

## TECHNICAL DRAWINGS

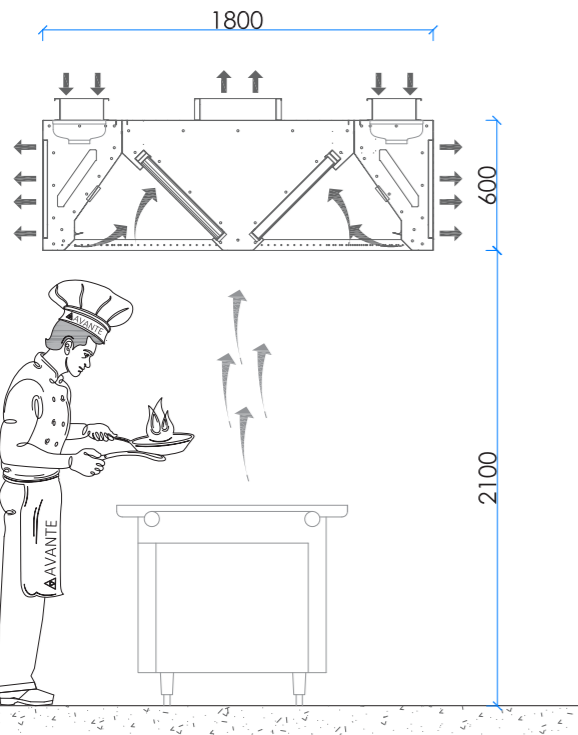

Island Hood

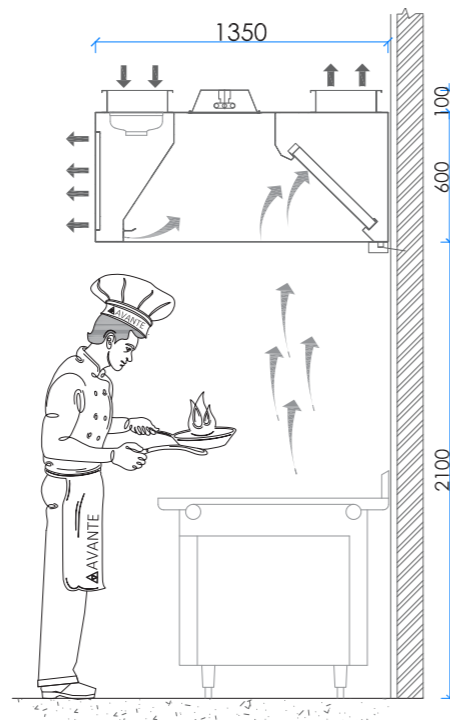

Wall mounted Hood

