

## HOODS

# AVANTE-EF

## HIGH EFFICIENCY EXTRACT-ONLY CANOPY WITH INDUCTION NOZZLES



Avante-EF is an extract-only canopy equipped with front and side induction nozzles to contain and extract fumes and heat within the hood area, thereby improving the extract efficiency and working conditions. The front section is equipped with a fan that uses the ambient air from the surrounding area to supply air through the induction nozzles.

### APPLICATION

- Avante-EF is designed with high-efficiency filtration capabilities and superior fire safety.
- Avante-EF is well-suited to all types of commercial and professional kitchens

### CUSTOMIZATION

- Wall mounted
- Island mounted
- 600mm height, 1350mm depth (min), length varies according to layout requirements

### MAINTENANCE

- Dripping grease is arrested with vane and collected in an easily accessible grease tray.

### OPTIONS

- LED dimmable spotlights
- Service Distribution Unit
- Factory-installed hood Fire Suppression System
- Factory-installed hood Demand Control Ventilation System
- Hood cladding / powder coating

# HOODS

## AVANTE-EF

### HIGH EFFICIENCY EXTRACT-ONLY CANOPY WITH INDUCTION NOZZLES

#### FILTRATION

- Heavy duty Stainless Steel welded construction
- Filtration efficiency of 95% for 6-8 microns
- UL listed
- DMT certified for filtration efficiency
- Meets NFPA #96 requirements.

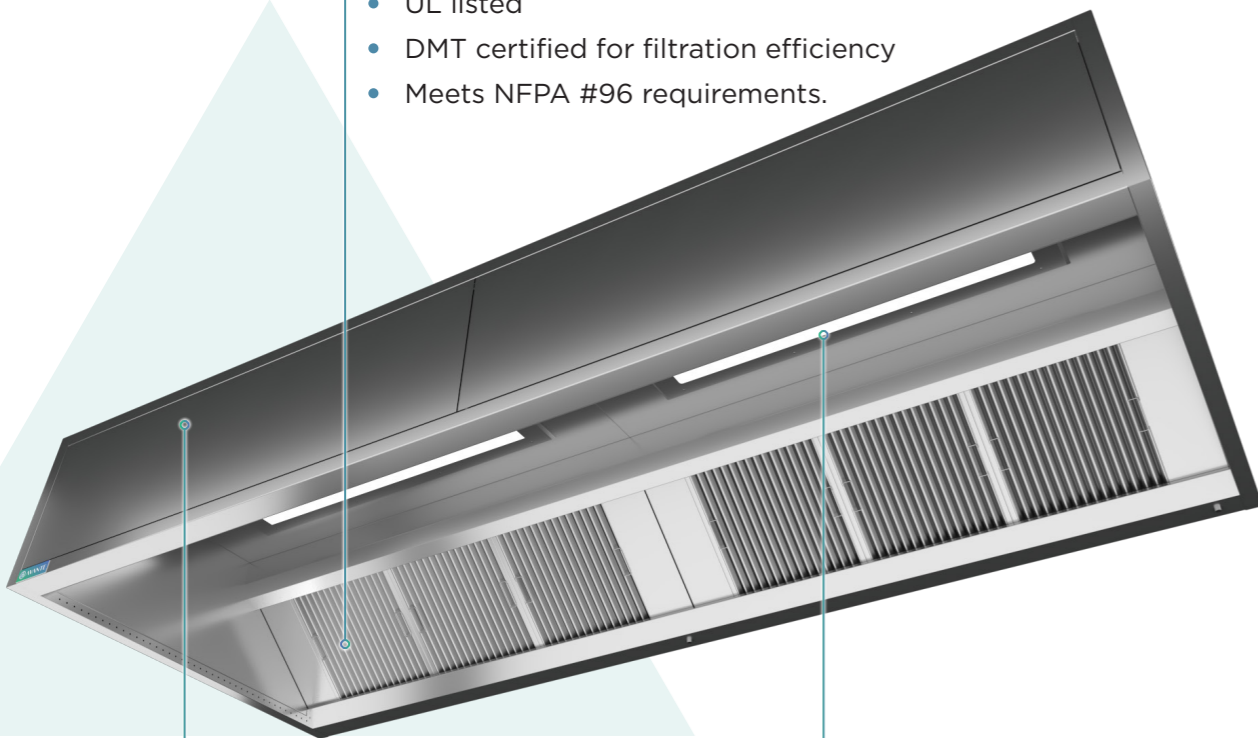

#### CONSTRUCTION

- Fully made of 1.2mm SS AISI 304 brush finish.
- Double skin
- Welded construction
- Full-length induction nozzle slot on the front and sides to improve the extraction efficiency.
- Sliding balancing dampers
- Extract air flow calculations as per DW 172
- Modular construction

#### LIGHTING

- Factory-wired
- Energy efficient fluorescent or LED lights (500 lux on the working surface - IP65)
- Tempered glass light diffuser with heat tolerance up to 180°C

#### TECHNICAL SPECIFICATIONS

##### MATERIAL:

- SS AISI 304 brush finish
- Thickness: 1.2mm

##### POWER SUPPLY:

- 120/220 - 240 V
- 50 - 60 Hz

##### LIGHTING:

- Fluorescent or LED lights
- Rated IP65
- 500 lux on the working surface
- Low consumption
- Heat & vapor resistance
- Long-lasting

##### DIMENSIONS:

- 600 mm (Height)
- 1350 mm (Depth min)
- Length: customized

#### GREASE FILTERS CERTIFICATIONS:



[www.avanteuae.com](http://www.avanteuae.com)



# HOODS

**AVANTE-EF** HIGH EFFICIENCY EXTRACT-ONLY CANOPY WITH INDUCTION NOZZLES

## TECHNICAL DRAWINGS

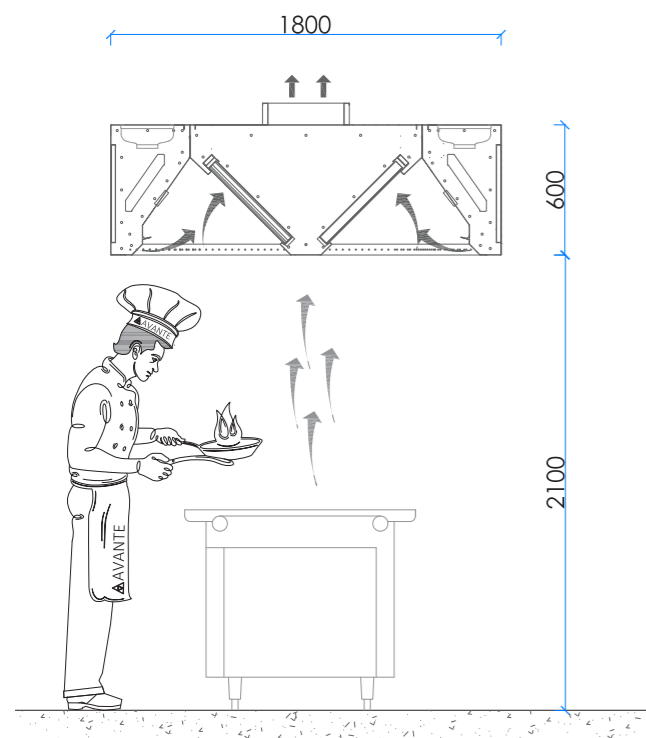

Island Hood

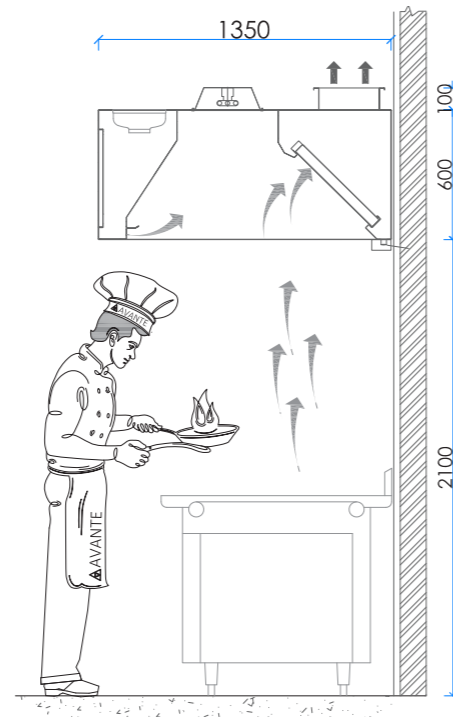

Wall mounted Hood

